

LED BATTEN LIGHT

Product&Family Code: 052 005 0150

TETRA/SQ-72

Technical Drawing

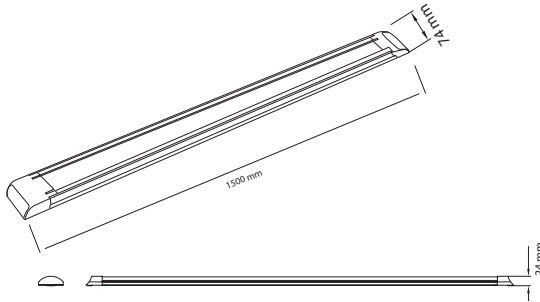

Technical Data	
Voltage (V)	175-250V
Product Wattage (W)	72
Equivalence with incandescent lamp(W)	576
Colour Render Index (Ra)	>Ra70
Colour Temperature (K)	6400K
Materials	PS + ALUMINIUM
Protection Class	II
Dimmable	No
EEI	A to A++
Warm-up time up to 60 % of the full light output	Instant Full Light
Luminous Flux (lm)	5670
Luminous Efficacy (lm/W)	79
Rated Life (hrs) ⌚	25.000
IP Rating	20
Power Factor	>0.5
Beam Angle	120°
Size (cm)	150
Number of ON-OFF cycling	x20.000

Photometric Diagram

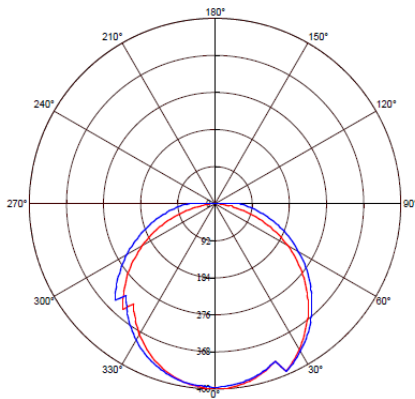

C0 Plane beam angle(50%): 113.7(DEG) C90 Plane beam angle(50%): 124.2(DEG)

Applications

- Designed indoor applications.



Features

- High Lumen and CRI, Good quality & Constant Current driver.
- High heat dissipation, low carbon and environmental protection.
- SMD LED Lamp Base.
- Very low energy consumption.

