

LED SOLAR STREET LAMP

Product&Family Code: 074 009 0300

GRAND-300

BLACK

Technical Drawing

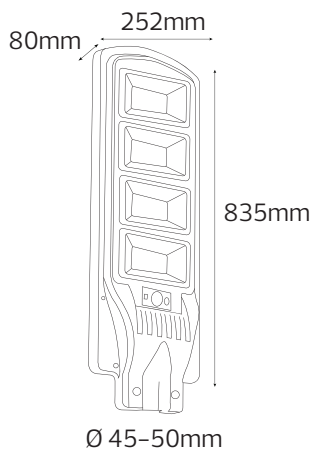

Technical Data

Voltage (V)	3 x 3.2V/5Ah Lithium Iron Phosphate
Product Wattage (W)	300
Colour Render Index (Ra)	>Ra70
Colour Temperature (K)	6400K
Materials	ABS + Photovoltaic
Protection Class	III
Dimmable	No
Warm-up time up to 60 %of the full light output	Instant Full Light
Luminous Flux (lm)	1567
Charging Time (h) :	4-6 (Cloudy 1 day, Rainy 2 days)
Duration Time (hrs) ⌚	12-15H
Solar Panel	6V/25W(Polycrystalline Silicon)
IP Rating	65
Beam Angle	120°
Irradiation Area (m2)	70
Installation Height(m)	5
Charging&Discharging Time:	> 1500

Applications

- Outdoor applications.



Features

- High Lumen and CRI, Good quality & Constant Current driver.
- High heat dissipation, low carbon and environmental protection.
- SMD LED Lamp Base.

